



# GRIPPERS

KG-2 KG-3

## SPECIFICATIONS

	BOTH	KG-2	KG-3
Fingers quantity		2	3
Actuation system	Under actuated		
Actuators	One per finger		
Actuators sensors	Current Temperature Rotational encoder		
Opening ( <i> fingertip</i> )	175 mm		
Object diameter for cylindrical grip	Minimum	55 mm	45 mm
	Maximum	100 mm	100 mm
Object diameter for on-the-ground pinch	8 mm min.		
Total weight		556 g	727 g
Gripping force		40 N	25 N
Opening or closing travel time	1.2 sec		
Operating temperature	-10 °C to 40 °C		

## CONTROLLER

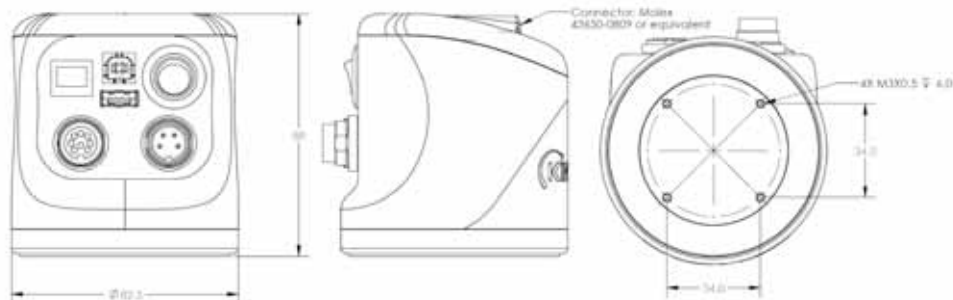

Ports	Joystick	1 Mbps Canbus
	Power supply	18 to 29 VDC
	USB 2.0 (API)	12 Mbps
	Ethernet (API)	100 Mbps
	Control system frequency	High level (API)
	Low level (API)	500 Hz
CPU		360 MHz
SDK	APIs	High and low level
	Compatibility	Windows, Linux Ubuntu & ROS
	Port	USB 2.0, Ethernet
	Programming languages	C++
Control		Force, cartesian & angular